

Extension spindles for Service and Gate Valves

MODEL: GV-ES-W

Features

- Easy access to underground mounted service and gate valves
- Protection against excessive vertical stress
- Fixed and telescopic options available

Optional Extras

- Adaptor for T-key
- Adaptor for stem

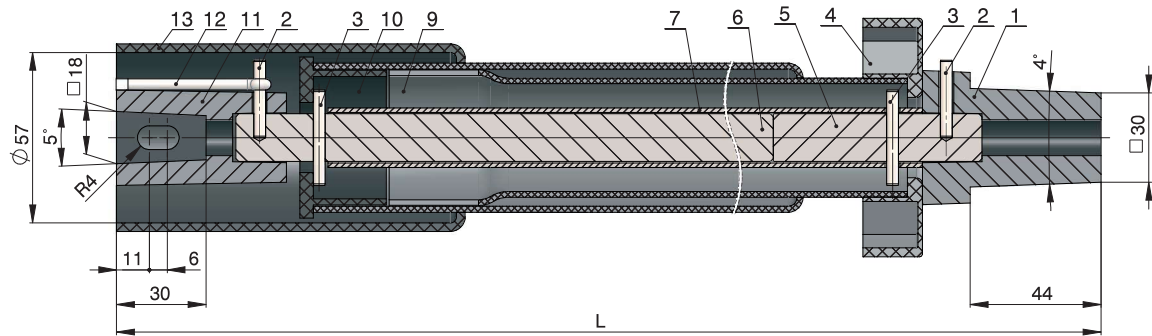

Material Specifications

Item	Part Name	Material	Grade
1	Upper stone	DI	EN-GJL-300 EN 1561
4	Collar	Plastic	PVC-U EN ISO 1163-1
5	Short square	Steel	S235JR EN 10025-2
6	Long square	Steel	S235JR EN 10025-2
7	Square tube	Steel	S235JR EN 10025-2
8	Inner tube	Plastic	PVC-U EN 1401-1
9	Outer tube	Plastic	PVC-U EN 1401-1
10	Lower cap	Plastic	PVC-U EN ISO 1163-1
11	Lower stone	Cast iron	EN-GJL-300 EN 1561
13	Bell	Plastic	PE EN 12201-2

Dimensions

Telescopic extension spindle (L=mm)

DN	550-800	700-1100	800-1200	1000-1650	1400-2200
20 - 150	•	•	•	•	•
150 - 300	•	•	•	•	•
600 - 1000	•	•	•	•	•
1000 - 1500	•	•	•	•	•
1500 - 1800	•	•	•	•	•

Fixed length extension spindle (L=mm)

DN	800	1000	1250	1500
20 - 150	•	•	•	•
150 - 300	•	•	•	•

Different length available on request