



## AVK SPRING KIT FOR SWING CHECK VALVES

41/32

001

AVK swing check valves with lever and external spring are suitable for installations with high pressure, insufficient back pressure and high flow velocities. The spring tension ensures fast and gentle closing which prevents water hammer. The lever and bracket are of ductile iron with blue epoxy coating and the spring, bolts, nuts and washers are of stainless steel.

### Product Description:

Swing check valve spring kit

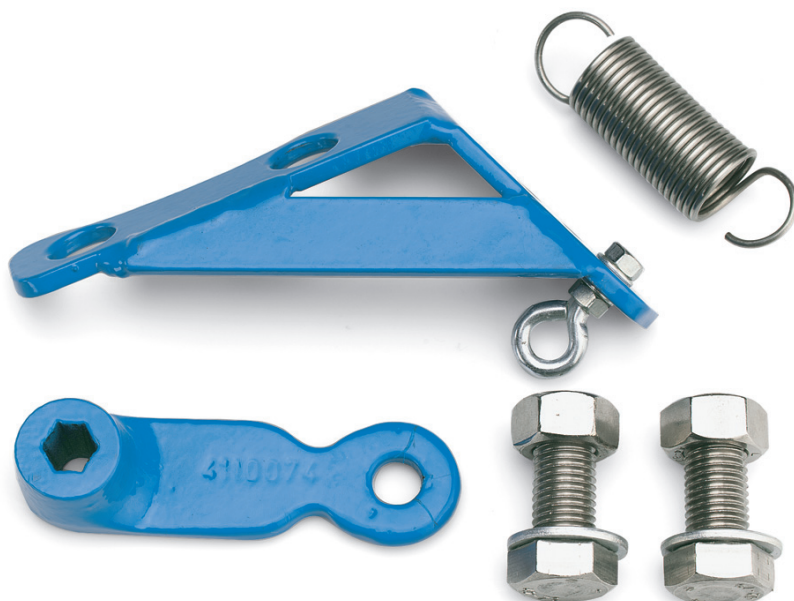

**AVK**

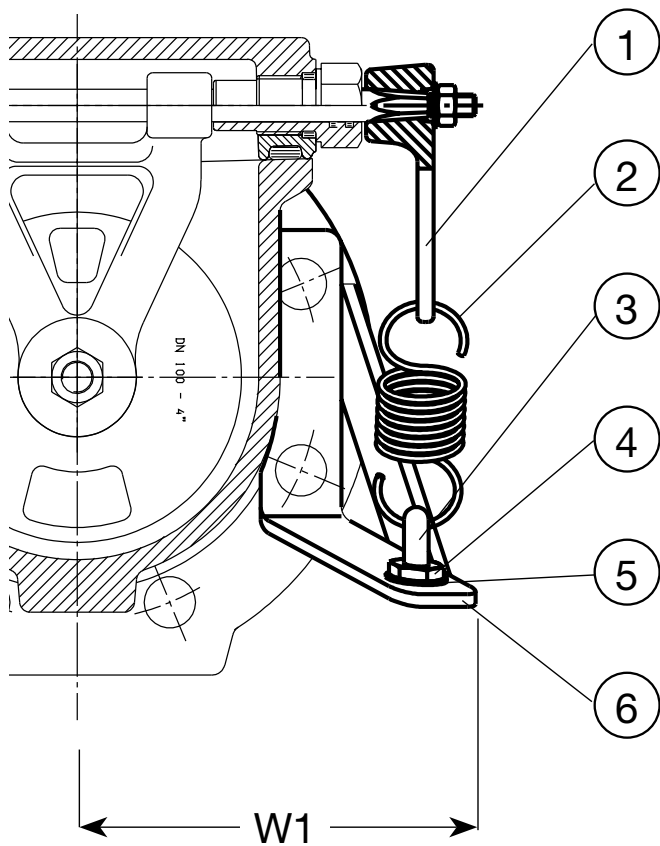

**Component List:**

1. Lever	Ductile iron	2. Spring	Stainless steel
3. Eye bolt	Stainless steel	4. Hexagon nut	Stainless steel
5. Washer	Stainless steel	6. Bracket	Ductile iron

Components may be substituted with equivalent or higher class materials without prior notification.

**Reference Nos. and Dimensions:**

AVK ref. nos	DN/DN mm	W1 mm	Theoretical weight kg
41-050-32-000	50 - 50	135	2.0
41-065-32-000	65 - 65	135	2.0
41-080-32-000	80 - 80	144	3.0
41-100-32-000	100 - 100	141	5.0
41-125-32-000	125 - 125	216	6.0
41-150-32-000	150 - 150	184	7.0
41-200-32-000	200 - 200	217	8.0
41-300-32-000	250 - 300	441	10