

# Restrained Flange Adaptor for PE/PVC Pipe

MODEL: FA-PE-H

## Features

- Nominal pressure designation: PN16
- Equipped with galvanized steel bolts, nuts
- EPDM or NBR rubber seals
- High Tolerance Mechanical Pipe Fittings
- Angular deflection +/- 6°
- FBE coated
- Flanges EN1092-2 PN10/16

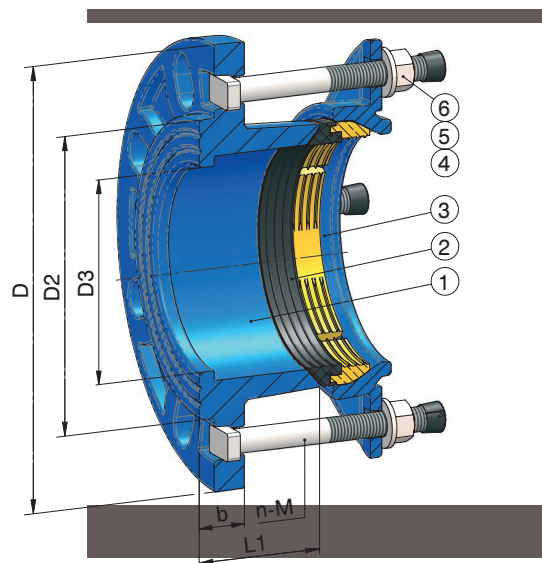

## Material Specifications

Item	Part Name	Material	Specification
1	Body	Ductile Iron	EN-JS-1050(EN-GJS-500-7) EN 1563
2	Sealing Ring	Rubber+Brass	NBR/EPDM+Brass
3	End Ring	Ductile Iron	EN-JS-1050(EN-GJS-500-7) EN 1563
4	Bolt	Zinc-plated steel	
5	Washer	Zinc-plated steel	
6	Nuts	Zinc-plated steel	

## Dimensions

Size	Pipe O.D.	D3	D	b	L1	M x L	Flange Designation PN10/PN16	Bolts Qty
DN50	63	55	180	18	63	M12 x 125	•	2
DN65	75	66	180	18	63	M12 x 125	•	2
DN80	90	84	180	18	63	M12 x 125	•	4
DN100	110	105	200	18	63	M12 x 125	•	4
DN125	125	125	220	18	63	M12 x 125	•	4
DN150	160	154	285	18	63	M12 x 125	•	4
DN200	200	200	340	18	63	M12 x 125	•	4
DN200	225	210	340	23	82	M12 x 175	•	4
DN250	250	250	400	26	82	M12 x 175	•	6
DN300	280	275	400	26	88	M12 x 175	•	6
DN300	315	302	455	26	88	M12 x 175	•	6