

Dismantling Joint

MODEL: DJ-U-H

Features

- Fusion bonded epoxy coating RAL5005/RAL5017
- Nominal pressure designation: PN10/16
- Sizes DN80-DN2200
- Free Movement: DN 80-2200 H = +/-25mm

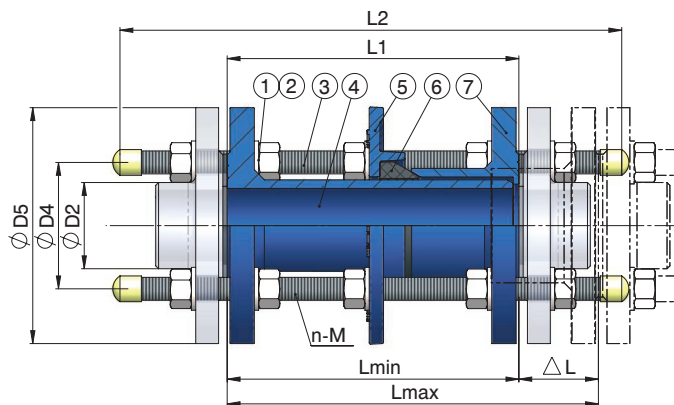

Material Specifications

Item	Part Name	Material	Specification
1	Washer	Zinc-plated steel	
2	Nut	Zinc-plated steel	
3	Stud	Zinc-plated steel	
4	Pipe	Ductile Iron	EN-JS 1050 (EN-GJS-500-7) EN1563
5	Middle Flange	Ductile Iron	EN-JS 1050 (EN-GJS-500-7) EN1563
6	Sealing Ring	Rubber	EPDM/EN 681-1
7	Outer Flange	Ductile Iron	EN-JS 1050 (EN-GJS-500-7) EN1563

Dimensions

DN	Pipe OD		Length		PN16 Flange Drilling			Weight
	D2	I1	I2	d4	d5	n - M		
80	98	200	310	160	200	8-M16	19	
100	118	200	310	180	220	8-M16	22	
125	144	200	310	210	250	8-M16	24	
150	170	200	320	240	285	8-M20	30	
200	222	220	340	295	340	12-M20	42	
250	274	230	370	355	400	12-M24	52	
300	326	250	410	410	455	12-M24	72	
350	378	260	410	470	520	16-M24	84	
400	429	270	430	525	580	16-M27	129	
450	480	270	430	585	640	20-M27	172	
500	532	280	440	650	715	20-M30	215	
600	635	300	480	770	840	20-M33	274	
700	738	300	480	840	910	24-M33	367	
800	842	320	520	950	1025	24-M36	409	
900	945	320	520	1050	1125	28-M36	472	
1000	1048	340	560	1170	1255	28-M39	580	
1100	1152	340	560	1270	1355	32-M39	668	
1200	1255	360	600	1390	1475	32-M45	987	
1400	1462	360	630	1590	1685	36-M45	1186	
1500	1565	400	665	1710	1820	36-M52	1466	
1600	1668	400	700	1820	1930	40-M52	1710	
1800	1875	420	730	2020	2130	44-M52	2011	
2000	2082	440	730	2230	2345	44-M52	2633	
2200	2288	450	750	2440	2555	52-M56	3200	